

SL11 USER MANUAL



TĒRĀDĒK

Copyright © 2024 AMIMON All rights reserved.

Amimon reserves the right to make changes to its products or specifications to improve performance, reliability, or manufacturability. Information furnished by Amimon is believed to be accurate and reliable. However, Amimon assumes no responsibility for its use. No license is granted by its implication or otherwise under any patent or patent rights of Amimon.

No part of this document may be produced or transmitted in any form or by any means, electronic or mechanical, for any purpose, without the express written permission of Amimon.

Data is subject to change without notification.

Amimon has patents and pending patent applications, trademarks, copyrights, or other intellectual property rights covering subject matter in this document. The furnishing of this document does not give any license to these patents, trademarks, copyrights, or other intellectual property rights except as expressly provided in any written agreement from Amimon.

Amimon is part of the Creative Solutions Division, which is part of Videndum PLC. Amimon's products are sold under the TERADEK professional video product line.

Contact us

International (M)	26 Zarhin St., Raanana, 4366250, Israel
EC REP	CEpartner4U Esdoornlaan 13, 3951 DB Maarn, The Netherlands +31.6.516.536.26
Website	Medical.teradek.com
TEL:	+972.9.962.9200



























Table of Contents

- 1. Before You Start
 - 1.1 Glossary of Symbols..... 5
 - 1.2 S/N Label..... 6
 - 1.3 Warning..... 7
- 2. Introduction
 - 2.1 System Description..... 8
- 3. Safety
 - 3.1 Introduction 10
 - 3.2 Operator..... 11
 - 3.3 Regulatory Warnings and Information..... 12
 - 3.4 Electrical and Mechanical Safety, and Fire Hazards..... 17
- 4. Installation
 - 4.1 System Installation 18
 - 4.2 View of the System 22
- 5. Operation
 - 5.1 Power and Connectivity..... 23
 - 5.2 Pairing..... 24
 - 5.3 User Interfaces..... 24

- 6. Maintenance
 - 6.1 Maintenance..... 26
 - 6.2 Waste Electrical and Electronic Equipment (WEEE) 26
- 7. Troubleshooting
 - 7.1 Troubleshooting 27
- 8. Technical Specifications
 - 8.1 Technical Specifications 29

1.1 Glossary of Symbols

The following are symbols that you will find throughout this operating manual and their meanings

	WARNING: The information stated where you will see this symbol is extremely important and must be noted!		Serial Number
	General Information		Wireless Transmission
	"Conformité Européene" Symbol (CE Marking)		Storage and Transport Humidity Range
	Waste of Electrical and Electronic Equipment (WEEE) Marking		DC Power Control
	Manufacturer		Storage and Transport Temperature Range
	Authorized Representative in the European Community		Refer to Instruction Manual/Booklet
	Manufacturer (accompanied by the name and address of the manufacturer)		Direct Current
	Date of Manufacture		Unique Device Identifier
	Medical Device		RF ID tag
	Country of Manufacturer		Batch Code
	Fragile		Model Number
	This Way Up		Translation
	Keep Dry		Non-Sterile
	Catalog Number		Compliance with Federal Communication Commission



1.2 S/N Label



SL11 Camera unit label on the device

Model: SL11TX01
Input:12-24V ----- Max.10W

CE **FC**

Contains:
FCC ID: VQSAMNPTTX01; HSW2832
IC: 7680A-AMNPTTX01; 4492A-2832









AMN_LBL_1055 Rev. 2.0

REF **MDWL1_SL11_AMN11** **AMIMON**

SN **1234-567890**

 (01)GTIN
(11)YYMMDD
(21)XXXXXX

YYYY-MM



Amimon Ltd.
26 Zarhin St.
Raanana
Israel

AMN_LBL_1056 Rev. 2.0

SL11 Camera unit label on individual device package

The label for the AMIMON Falco SL11 wireless camera contains the following information:

- AMIMON** logo
- Falco SL11 wireless camera**
- Model: SL11TX01**
- Input: 12V-24V ----- Max. 10W**
- CE and FCC certification marks
- Contains: FCC ID: VQSAMNPTTX01; HSW2832; IC: 7680A-AMNPTTX01; 4492A-2832
- EC REP: CEpartner4U, Esdoornlaan 13, 3951 DB Maarn, The Netherlands, +31.6.516.536.26
- CH REP: MedEnvoy Switzerland, Gotthardstrasse 28, 6302 Zug, Switzerland
- REF: MDMP1_SL11_1STE12
- SN, UDI, MD boxes
- Humidity and temperature icons: 15% RH, 90% RH, -20°C, 60°C
- AMN_LBL_1057 Rev. 2.0
- Amimon Ltd. 26 Zarhin St. Raanana Israel, 888.941.2111 (USA), +972-9-9629200 (Outside USA)
- Made in Taiwan
- Waste disposal symbol

1.3 Warning



The SL11 system is designed for professional use only. The manufacturer cannot be held responsible for damage or injury caused by improper use or for uses other than those for which this machine is intended.

Read the User Manual instructions carefully before using the system to become familiar with all safety requirements and operating procedures thereby preventing accidents and injury while reducing the risk of damaging the machine. Any unauthorized change or modification to the SL11 devices is prohibited and can result in hazard or injury.

2.1 System Description

Models

Camera unit: SL11TX01

Receiver: MD11RX01

Sterilizable cover: AMN_ASM_1030

Description

Falco SL11 is a wireless camera designed for medical applications, providing ultra-low latency video up to 4K30 FPS. It can capture detailed procedures and deliver sharp, clear images from surgical lights, treatment room lights, suspended arms, and various setups. The technology enables seamless wireless transmission of live video to monitors, control panels, recording equipment, and other devices, ensuring robustness and flexibility in operating rooms and clinical settings. The video can be received by an MD11 receiver or other receivers within the Falco product family. The SL11 comes with a sterilizable handle accessory, allowing for easy operation and adjustment of the camera's position during procedures.

Intended Use and Environment

The SL11, a wireless camera with an embedded transmitter, is intended for use in professional healthcare facility environments, such as physician offices, dental offices, clinics, limited care facilities, freestanding surgical centers, freestanding birthing centers, multiple treatment facilities, hospitals, emergency rooms, patient rooms, intensive care, surgery rooms except near HF SURGICAL EQUIPMENT, outside the RF shielded room of a SYSTEM for magnetic resonance imaging.

The SL11 is designed to deliver wireless video for training, educational, and recording purposes.

This SL11 is intended for use by healthcare professionals only within the professional healthcare facility environment, out of the sterile field.

Limitations of Use

The SL11 is a non-sterile, reusable device and is not intended for use within a sterile field without the sterilizable cover. The sterilizable cover shall be sterilized before each procedure, according to the requirements specified in the sterilizable cover user manual.

System Dimensions

Camera Unit

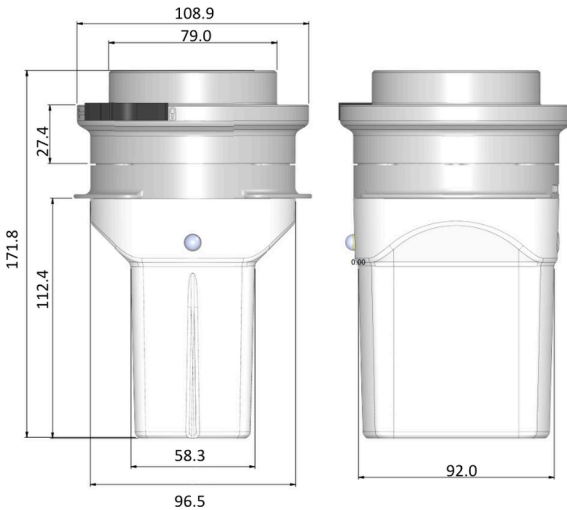

Sterilizable Cover

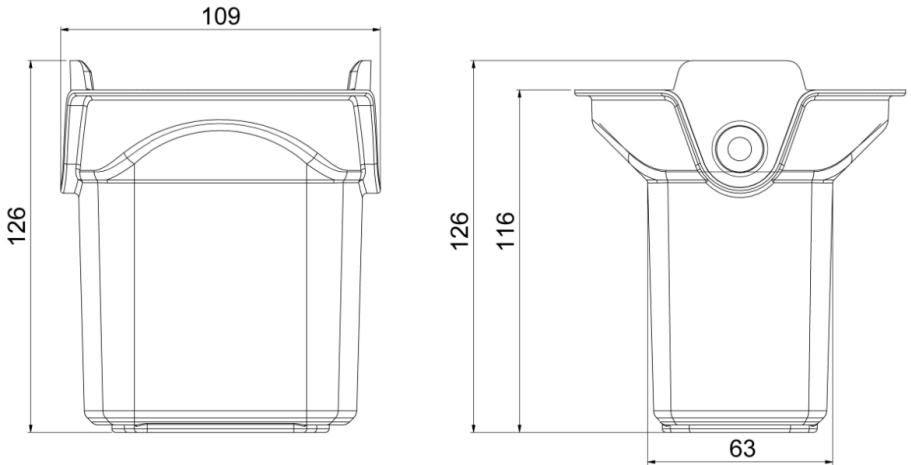

3.1 Introduction



This chapter describes safety issues regarding the use and maintenance of the System, with special emphasis on electrical safety. Please carefully read this chapter and be familiar with all of its safety requirements and operating procedures before operating the System.

The System is designed for a safe and reliable treatment when used in accordance to proper operating and maintenance procedures as outlined in this operating manual. Only healthcare professionals can use the system and perform the treatments. The operator and all other personnel operating or maintaining the System should be familiar with all the safety information provided in this manual.

The primary objective should always be to maximize the safety of both the client and the treatment operator.



WARNING: Use of accessories, transducers, and cables other than those specified or provided by the manufacturer of this equipment could result in increased electromagnetic emissions or decreased electromagnetic immunity of this equipment and result in improper operation.



WARNING: The video transmitter system, model SL11 needs special precautions regarding EMC and needs to be installed and put into service according to the specific instructions for maintaining basic safety and essential performance concerning electromagnetic disturbances for the expected service life provided in regulatory warning section in this chapter.

3.2 Operator

- All operators **MUST** be familiar with the system controls and know how to shut down the system in case of trouble.
- Always be aware of the possible dangers of using the System and take proper precautions as described in this manual.
- Do not touch the inner parts of the System. The System repairs must be performed by qualified personnel only. Failure to do so will void all service agreements.
- Do not touch the device for a period longer than 10 seconds, to avoid excessive exposure to temperature.

3.3 Regulatory Warnings and Information

Modifications

Any changes or modifications could void the user's authority to operate the equipment and invalidate the regulatory approval.

Antenna Requirements

The product is provided with approved antennas. Use only antennas supplied by Amimon. Any changes or modifications to the antenna may void the regulatory approvals obtained for the product.

FCC STATEMENT

The following antennae were approved with the modules listed in the **Antenna Information** table.

INDUSTRY CANADA (IC) STATEMENT

The radio transmitters 7680A-AMNPTTX01, 7680A-AMN42012, and 4492A-2832 have been approved by Industry Canada to operate with the antenna types listed below with the maximum permissible gain indicated. Antenna types not included in this list, having a gain greater than the maximum gain indicated for that type, are strictly prohibited for use with this device.

Under Industry Canada regulations, this radio transmitter may only operate using an antenna of a type and maximum (or lesser) gain approved for the transmitter by Industry Canada. To reduce potential radio interference to other users, the antenna type and its gain should be so chosen that the equivalent isotropically radiated power (e.i.r.p.) is not more than that necessary for successful communication

Les présent émetteur radios 7680A-AMNPTTX01, 7680A-AMN42012 et 4492A-2832 ont été approuvé par Industrie Canada pour fonctionner avec les types d'antenne énumérés ci-dessous et ayant un gain admissible maximal et l'impédance requise pour chaque type d'antenne. Les types d'antenne non inclus dans cette liste, ou dont le gain est supérieur au gain maximal indiqué, sont strictement interdits pour l'exploitation de l'émetteur.

Conformément à la réglementation d'Industrie Canada, le présent émetteur radio peut fonctionner avec une antenne d'un type et d'un gain maximal (ou inférieur) approuvé pour l'émetteur par Industrie Canada. Dans le but de réduire les risques de brouillage radioélectrique à l'intention des autres utilisateurs, il faut choisir le type d'antenne et son gain de sorte que la puissance isotrope rayonnée équivalente (p.i.r.e.) ne dépasse pas l'intensité nécessaire à l'établissement d'une communication satisfaisante.

Antenna Information					
Medical Device	Module Model	FCC ID	IC	Model	Gain
SL11TX01	AMNPTTX01	VQSAMNPTTX01	7680A-AMNPTTX01	2x AMN_ANT_1012-0	0dBi Typical
SL11TX01	MBN52832	HSW2832	4492A-2832	AMN_ANT_1022	1dBi Typical

RF Exposure

EU AND INTERNATIONAL STATEMENT

The product complies with internationally recognized standards covering human exposure to electromagnetic fields from radio devices. To satisfy local RF exposure regulation requirements, the transmitting product must operate with a minimum separation distance of 20 cm or more from a person's body.

FCC RF EXPOSURE STATEMENT

This equipment complies with the FCC RF radiation exposure limits set forth for an uncontrolled environment. This equipment should be installed and operated with a

minimum distance of 20 centimeters between the radiator and your body. This transmitter must not be co-located or operating in conjunction with any other antenna or transmitter.

IC RADIATION EXPOSURE STATEMENT

Important Note: Radiation Exposure Statement

This equipment complies with IC radiation exposure limits set forth for uncontrolled environments. This equipment should be installed and operated with a minimum distance of 20cm between the radiator and your body.

Note Importante: Déclaration d'exposition aux radiations

Cet équipement est conforme aux limites d'exposition aux rayonnements IC établies pour un environnement non contrôlé. Cet équipement doit être installé et utilisé avec un minimum de 20 cm de distance entre la source de rayonnement et votre corps.

Unintentional Radio Interference

If this equipment does cause interference to radio or television reception, which can be determined by turning the equipment off and on, the user is encouraged to try to correct the interference by one or more of the following measures:

- Reorient or relocate the system
- Increase the separation between the equipment and the system

Radio Transmitters

General

- Operation of these devices in the 5.925-6.425 GHz band is prohibited on oil platforms, cars, trains, boats, and aircraft, except that operation of this device is permitted in large aircraft while flying above 10,000 feet
- Operation of these devices in the 5.925-6.425 GHz band is prohibited for control of or communications with unmanned aircraft systems.
- Any changes or modifications not expressly approved by the party responsible for compliance could void the user's authority to operate the equipment.

- In the 5.925-6.425 GHz band, devices containing AMN42012 (which is a client device) must operate under the control of a device containing the AMNPTTX01 which is an indoor access point. In all cases, an exception exists for transmitting brief messages to an access point when attempting to join its network after detecting a signal that confirms that an access point is operating on a particular channel. Access points may connect to other access points. Client devices are prohibited from connecting directly to another client device.

FCC STATEMENT: Radio Transmitters (Part 15) – Class B Digital Devices

This device complies with Part 15 of the FCC Rules. Operation is subject to the following two conditions:

1. This device may not cause harmful interference, and
2. This device must accept any interference received, including interference that may cause undesired operation.

FCC regulations restrict the operation of these devices in the 5.925-6.425 GHz band to indoor use only.

IC STATEMENT

This device contains license-exempt transmitter(s)/receiver(s) that comply with Innovation, Science, and Economic Development Canada's license-exempt RSS(s).

Operation is subject to the following two conditions:

1. This device may not cause harmful interference, and
2. This device must accept any interference received, including interference that may cause undesired operation.

Le présent appareil est conforme aux CNR d'Industrie Canada applicables aux appareils radio exempts de licence. L'exploitation est autorisée aux deux conditions suivantes:

1. l'appareil ne doit pas produire de brouillage.
2. l'utilisateur de l'appareil doit accepter tout brouillage radioélectrique subi, même si le brouillage est susceptible d'en compromettre le fonctionnement.

Caution:

1. The device for operation in the band 5150-5250 MHz is only for indoor use to reduce the potential for harmful interference to co-channel mobile satellite systems.
2. Users should also be advised that high-power radars are allocated as primary users (i.e. priority users) of the bands 5250-5350 MHz and 5650-5850 MHz and that these radars could cause interference and/or damage to LE-LAN devices.
3. The maximum antenna gain permitted for devices in the bands 5250-5350 MHz and 5470-5725 MHz shall be such that the equipment still complies with the e.i.r.p. limit.
4. The maximum antenna gain permitted for devices in the band 5725-5850 MHz shall be such that the equipment still complies with the e.i.r.p. limits specified for point-to-point and non-point-to-point operation as appropriate.
5. Operation is limited to indoor use only in the band 5925-6425 MHz;
6. Operation on oil platforms, cars, trains, boats, and aircraft shall be prohibited except for on large aircraft flying above 10,000 ft.

Avertissement:

1. Les dispositifs fonctionnant dans la bande 5150-5250 MHz sont réservés uniquement pour une utilisation à l'intérieur afin de réduire les risques de brouillage préjudiciable aux systèmes de satellites mobiles utilisant les mêmes canaux;
2. De plus, les utilisateurs devraient aussi être avisés que les utilisateurs de radars de haute puissance sont désignés utilisateurs principaux (c.-à-d., qu'ils ont la priorité) pour les bandes 5250-5350 MHz et 5650-5850 MHz et que ces radars pourraient causer du brouillage et/ou des dommages aux dispositifs LAN-EL.
3. Le gain d'antenne maximum autorisé pour les appareils fonctionnant sous les bandes de fréquences 5250-5350 MHz et 5470-5725 MHz doit être tel que l'équipement est toujours conforme à la limite PIRE;
4. Le gain d'antenne maximum autorisé pour les appareils fonctionnant sous les bandes de fréquences 5725-5850 MHz doit être tel que l'équipement est toujours conforme à la limite PIRE spécifiée pour un fonctionnement point à point et non point à point, le cas échéant.
5. Utilisation limitée à l'intérieur seulement dans la bande 5925 – 6425 MHz;
6. Utilisation interdite à bord de plateformes de forage pétrolier, de voitures, de trains, de

bateaux et d'aéronefs, sauf à bord d'un gros aéronef volant à plus de 10,000 pieds d'altitude

EU COMPLIANCE STATEMENT

Amimon Ltd. hereby declares that these Radio Transmitters are in compliance with the essential requirements and other relevant provisions of Directives 2014/53/EC, 2011/65/EU and (EU) 2015/863. The full text of the EU DoC is located at:

<https://www.medical.teradek.com/falco-sl11>.

3.4 Electrical and Mechanical Safety, and Fire Hazards

Damage due to inappropriate handling is not covered by the warranty.

Portable RF communications equipment (including peripherals such as antenna cables and external antennas) should be used no closer than 30 cm (12 inches) to any part of the SL11 system. Otherwise, degradation of the performance of this equipment could result.

Fire Hazards



WARNING:

- **Do not use the system in the presence of explosive or flammable materials.**
- **Do not use the system in an oxygen-rich environment.**

Equipment List

When you receive the system, ensure that it includes the following pieces of equipment:

- SL11 – transmitter
- MD11RX – receiver & AC adapter*
- Sterilizable cover *

* Not included in the SL11 package.

Electrical Requirements



The SL11 is powered by the Theater light.

- **Power input - 12V – 24V DC**
- **Typical Power Consumption - 10W**

Environmental Requirements

- Corrosive materials can damage electronic parts. Ensure that the environment is free from corrosive material.
- For optimal operation, the system should be placed in a room with temperatures between 0°- 40°C (32°-104°F) and relative humidity between 25-75%.
- For optimal storage, the system should be stored at a temperature between -20°- 60°C (-4°-140°F) with a relative humidity between 15-90%.
- For optimal transportation system should be transported under the temperature range between -20°- 60°C (-4°-140°F) with a relative humidity of less than 80%.

4.1 System Installation

Installation

The SL11 is installed on the surgical light as a handle. The MD11 Receiver can be installed horizontally on a cart or vertically on a monitor using a VESA plate.



WARNING:

- Make sure the locking mechanism of the SL11 is secured to the light head, to keep the SL11 from falling from the light head.
- The SL11 sterilizable cover must be sterilized before every operation as instructed in the User Manual.

- The MD11 Receiver is not intended for use near patients, or medical staff (minimum distance 20cm between the radiator and your body).
- Do not install near sources of intense heat, such as boilers or radiators.
- Install this system in an environment that complies with all applicable IEC, CEC, and NEC requirements for safety of electrical devices. Any installation or connection with other devices shall be evaluated for electrical safety according to the IEC 60601-1.

Distance Between Falco Devices

This section describes the required distance and limitations between installed Falco devices (such as Falco MD11).

- The distance between a paired transmitter and receiver shall be between 1m and 10m.
- There is no distance limitation between receivers paired with the same transmitter.

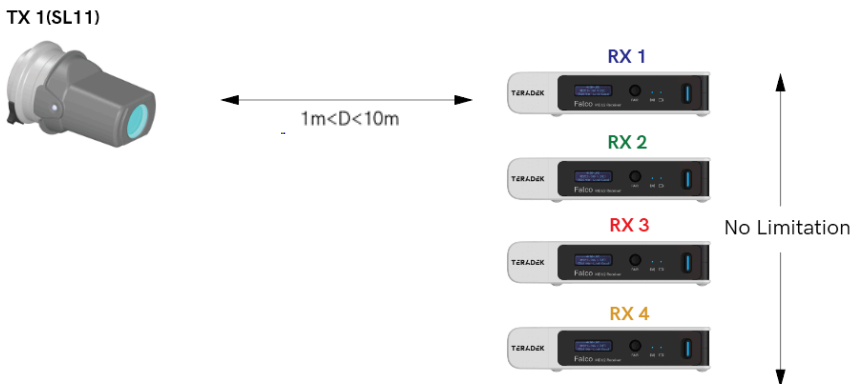

D = Distance

- The distance between neighboring Falco transmitters shall be no less than 1m

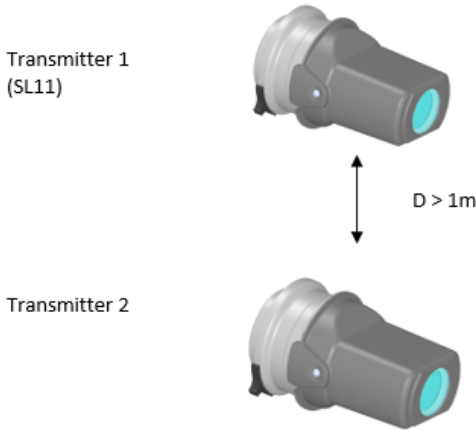

- The distance between any transmitter and any receiver (not part of the link) shall be no less than 2m.

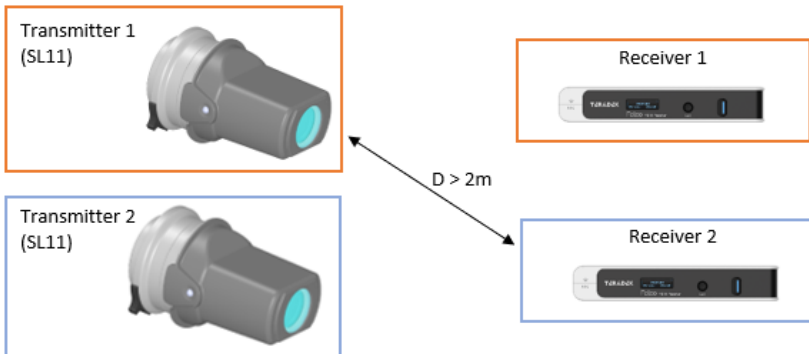

- The distance between receivers (linked to different transmitters) shall be no less than 80 cm.



- The maximum number of Falco devices to be operated in a single room is six transmitters and six receivers.
- The room may also contain other RF-emitting devices, such as 2.4GHz or 5GHz Wi-Fi and 2.4GHz Bluetooth.

4.2 View of the System

SL11 Camera Unit

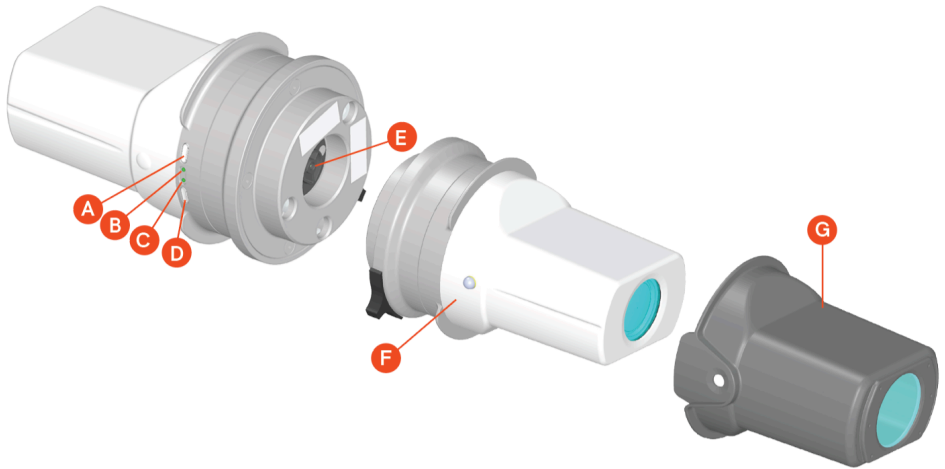

A: Pairing button

B: Network LED (Blue)

C: Video LED (Green)

D: Reset button

E: Host connector

F: Sterilizable cover release button

G: Sterilizable cover

MD11 Receiver

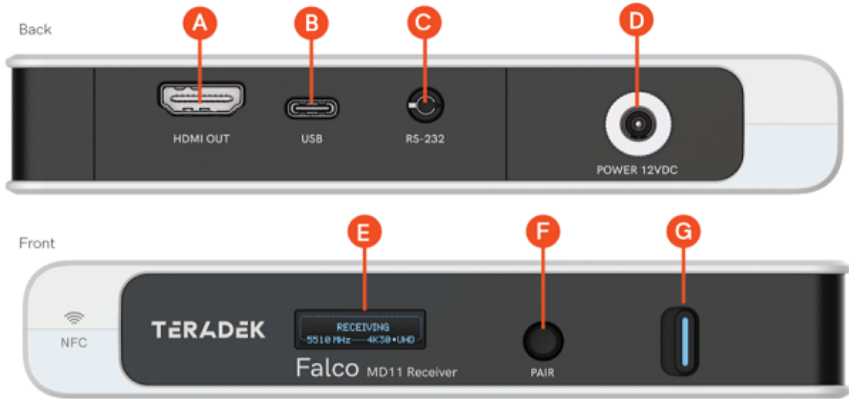

- A. HDMI output
- B. USB-C port
- C. RS-232
- D. 12V DC power input
- E. OLED display
- F. Navigation button
- G. On/Off switch

5.1 Power and Connectivity

1. Connect power to the receiver using the included AC adapter.
2. Connect the receiver's HDMI output (A) to the video input on your monitor.
3. Slide the power switch on the receiver to the **ON** position. Follow the Pairing process described hereunder and the receiver will connect to the SL11 and start delivering video.

4. To turn off the device, slide the power switch (**G**) to the **OFF** position and ensure the blue light turns off.
5. USB-C (B) available for future software updates.

5.2 Pairing

To associate the SL11 transmitter with the MD11 receiver, the devices need to be paired using the dedicated buttons.

1. Press the Pair button on the SL11 (A) for 5 seconds, and wait for the network LED to indicate that the pairing process has started.
2. Press the Navigation button on the MD11 receiver (G) for 5 seconds to start the pairing process. The OLED display will indicate pairing has started. **NOTE: Pressing the navigation button for 5 seconds will start the Pairing process without unlocking the menu.**
3. When pairing two to four receivers with one transmitter, repeat steps 1 and 2 for each receiver to be paired. Once a receiver is paired, turning it off before pairing the next receiver device is recommended.
4. When a fifth receiver is paired with a transmitter, the first paired receiver is deleted automatically from the transmitter's list of paired receivers. This receiver will stop showing video.
5. Falco SL11 can also pair with Falco MD62 devices. To pair the SL11 device with a Falco MD62 device, follow the pairing instructions for the MD62.

5.3 User Interfaces

SL11 User Interface

- **Pairing Button** - The SL11 includes a Pairing button (**A**) for pairing the SL11 with receivers. See [Pairing](#) instructions for further details. The button is covered by the sterilizable cover during operation.
- **Reset Button** – The SL11 includes a Reset button (**D**), used to reset the device without disassembling it from the light-head, once installed. The button is covered by the sterilizable cover during operation.

SL11 LEDs

The SL11 LEDs indicate the status of the Network (Blue) and Video (Green) states. Each LED can be Off, On (solid light), or in a blink state.

There are three blink speeds used to differentiate between states – Fast, Medium, and Slow.

- **Slow blink** - LED state changes every 1 sec.
- **Medium blink** - LED state changes every 500 msec.
- **Fast blink** - LED state changes every 100 msec.

SL11 STATUS LEDs			
#	Status	Network LED	Video LED
1	No link	Off	
2	Searching for free frequency	Slow	
3	Network connecting	Medium	
4	Network connected	On	
5	Pairing in progress	Fast	
6	System is stuck in boatloader	Medium	Medium
7	No video		Off
8	Video real		Off

Camera Control

The control on the SL11 Camera Unit is controlled by VISCA protocol, over RS232.

6.1 Maintenance

No maintenance is required.



Cleaning and Maintenance Warning:

- Unplug the SL11 from the power source before cleaning, to avoid electric shock and potentially fatal injury.
- The SL11 is a non-sterile product. It is required to use the sterilizable cover when the SL11 is used in a sterile environment

CAUTION:

- Do not use the system near liquids. The system shall not be exposed to dripping or splashing liquids.
- Clean only with dry cloth.

The sterilizable cover shall be sterilized before each procedure, according to the requirements specified in the sterilizable cover user manual.

6.2 Waste Electrical and Electronic Equipment (WEEE)

Waste electrical and electronic equipment should not be disposed of with household waste. Please recycle where facilities exist. Check with your local authority or retailer for recycling advice.

7.1 Troubleshooting

The MD11 Receiver unit does not power on.

- a. Verify the power adaptor is connected and the power switch is in 'On' position.
- b. Power cycle the unit, by switching the power button to 'Off' and then back to 'On' position.

The SL11 Camera unit does not power on.

- a. Verify the host connector is connected properly.
- b. Power cycle the unit, by disconnecting and connecting the host connector.

The MD11 Receiver shows a "NOT PAIRED" message on the OSD.

Pair the SL11 with the Receiver unit. Visit the [Pairing](#) section (5.2) for detailed instructions

The MD11 Receiver unit shows a "NO LINK" message.

- a. Verify that the "paired" SL11 is turned ON.
- b. If the SL11 is in "Network Connecting" mode for over a minute, power cycle (turn OFF then ON) both the SL11 and the MD11 receiver.
- c. If the paired SL11 is in "Searching for Frequency" mode, wait at least two minutes.
- d. Keep at least a one meter distance between the SL11 and the MD11 receiver.
- e. Re-pair the units.

There is no video signal on the monitor.

- a. Verify the Navigation Screen of the Receiver indicates "**Connected to <TX name>**" message.
- b. Verify the HDMI cable connected to the Receiver unit supports 4K video resolution.
- c. Verify that the monitor supports 4K resolution.

The video is displayed with artifacts.

- a. Confirm the SL11 Camera and Receiver units are positioned in the same room, with a distance of less than 30m.
- b. Validate that there are no obstacles (walls, metal plate, etc.) between the two units.
- c. Check that the two units are located at least 1 meter from each other.

- d. Verify that there is no other wireless unit located near the SL11 Receiver unit.
- e. Verify that the sterilizable cover is clean and unscratched.

The Video LED indicator of the SL11 Camera unit is blinking.

There is a problem with the camera. Power cycle the SL11 Camera unit by pressing the Reset button, or by disconnecting and connecting the host connector. If the video LED is still blinking, contact your Reseller for further instructions.

8.1 Technical Specifications

	FALCO SL11 CAMERA UNIT	FALCO MD11 RECEIVER
VIDEO		
Video Outputs	N/A	1x HDMI 1.4 Type-A output
Color Sampling	N/A	10-bit/HDMI: RGB 4:4:4 8-bit
Delay (TX to RX)	<0.001sec	<0.001sec
Supported Resolutions	4Kp23.98/29.97 1080p23.98/25/29.97/30/50/ 59.94	4Kp23.98/24/25/29.97/30 1080p23.98/24/25/29.97/30/50/ 59.94/60 1080i50/59.94/60 720p50/59.94/60
Video Camera	Camera: Sony FCB-ER8530 Zoom: 20x Optical, 12x Digital Camera Control: VISCA	N/A
PHYSICAL ATTRIBUTES		
Dimensions	4" x 6.4" [96mm x 171mm]	6" x 3.1" x 1" (151.4 x 79 x 25mm)
Weight	31.6oz [898g]	11.2oz (317g)
INTERFACES		
Buttons	Pairing and Reset buttons	Navigation button for control and configuration

Host Connector	A proprietary connector for power and VISCA control for the camera.	N/A
OLED	N/A	Status and Configuration Display
LED	Wireless, Video	N/A
BLE and NFC	N/A	Control and configuration
Switches	N/A	On/Off Switch
USB Interface	N/A	Update via USB-C
Device Control	VISCA using host connector	RS-232 (for future use)

WIRELESS VIDEO NETWORK

Wireless Video Bands	DFS Frequencies: 5.270 ~ 5.310 GHz and 5.510 ~ 5.710 GHz	DFS Frequencies: 5.270 ~ 5.310 GHz and 5.510 ~ 5.710 GHz
	Non-DFS Frequencies: 5.190 ~ 5.230 GHz and 5.750 ~ 5.830 GHz	Non-DFS Frequencies: 5.190 ~ 5.230 GHz and 5.750 ~ 5.830 GHz

NOTE: Frequencies and channels are dependent on regional approvals.

Bandwidth	40MHz	20MHz/40MHz
Modulations	OFMD	OFMD
RF Power	15dBm EIRP	14dBm EIRP
Antennas	2x Internal 0dBi antennas	5x Internal 2dBi antennas

Encryption	AES-256, RSA-1024 key exchange	AES-256, RSA-1024 key exchange
Range	Up to 100 ft (30m)	Up to 100 ft (30m)
Multicast	Transmitter can stream simultaneously to up to 4 receivers	Receiver can switch between 4 transmitters
Noise Rejection	Can coexist with WiFi and other devices working on the 5GHz band. Up to 6 sets at the same location.	Can coexist with WiFi and other devices working on the 5GHz band. Up to 6 sets at the same location.

POWER

Power Input	12-24 VDC	12 VDC
-------------	-----------	--------

Nominal Power Consumption	10 Watts	7 Watts
---------------------------	----------	---------

GENERAL

Mountability	Customizable back side	It can be mounted on a VESA Plate and be placed in any position.
--------------	------------------------	------------------------------------------------------------------

CERTIFICATION AND APPROVALS

General	ISO 13485:2016 MDR 2017/745 Class I FDA Manufacturer Registration 3014730563 FDA Listing Class I, 510K exempt.
---------	-------------------------------------------------------------------------------------------------------------------------

CFR 21 Parts 801, 807, 820, 880
UK MDR 2002

Medical
Electrical
Equipment

IEC 60601-1:2005 + A1:2012 + A2:2020, EN 60601-1:2006 + A1:2013 + A2:2021, ANSI/AAMI ES60601-1:2005+ A1:2012 + A2:2021, CAN/CSA-C22.2 No. 60601-1:14 + A2:2022
IEC 60601-1-6:2010+A1:2013+A2:2020 for use in conjunction with IEC 62366-1:2015+A1:2020 and IEC 60601-1:2005+A1: 2012+A2: 2020
EN 60601-1-6:2010+A1:2015+A2:2021 for use in conjunction with EN 62366-1: 2015+A1:2020 and EN 60601-1:2006+A1:2013+A2:2021
IEC 60601-1-2:2014 + A1:2020, EN 60601-1-2:2015 + A1(21) Edition 4.1, CISPR 11:2015 + A1(16) and A2(19) group 1 class B limits
EN/IEC 60601-2-41: 2021 (clause 201.9) for use in conjunction with IEC 60601-1:2005+A1:2012+A2:2020 and clause 201.17

Materials

Regulation (EC) No 1907/2006,
Directive 2011/65/EU & (EU) 2015/863

Radio

FCC CFR 47 Part 15, FCC CFR 47 Part 2
RE-Directive 2014/53/EU: EN 301 893 V2.1.1, EN 300 328 V2.2.2, EN 50385:2017
Electromagnetic Compatibility - EN 301 489-1 V2.2.3, EN 301 489-17 V3.2.4, Class B

Electromagnetic Compatibility

- This equipment is for use in a professional healthcare environment. It is not for use in the RF-shielded room of a medical electrical system for magnetic resonance imaging, where the intensity of EM disturbances is high.
- This equipment is not likely susceptible to interference from HF surgical instruments in the Special Environment of being near an active HF surgical instrument. In the case

that HF surgical interference is observed, adjust the separation distance of the equipment.

Guidance and Manufacturer's Declaration - ELECTROMAGNETIC IMMUNITY

The SL11 Wireless Camera and MD11 Receiver are intended for use in the electromagnetic environment specified below. The customer or the user of the SL11 Wireless Camera and MD11 Receiver should ensure that they are used in such an environment.

Guidance and Manufacturer's Declaration: ELECTROMAGNETIC EMISSIONS		
The SL11 Camera Unit and MD11 Wireless Receiver are intended for use in the electromagnetic environment specified below.		
The customer or the user of the SL11 Camera Unit and MD11 Wireless Receiver should ensure they are used in such an environment.		
Emissions Test	Compliance	Electromagnetic Environment - Guidance
RF emissions CISPR 11	Group 1	The SL11 Camera Unit and MD11 Wireless Receiver use RF energy only for their internal function; therefore, their RF emissions are very low and are not likely to cause any interference in nearby electronic equipment.
RF emissions CISPR 11	Class B	The SL11 Camera Unit and MD11 Wireless Receiver are suitable for use in all establishments other than domestic establishments and those directly connected to the public low-voltage power supply network that supplies buildings used for domestic purposes, provided the following warning is heeded:
Harmonic emissions IEC 61000-3-2	Class A	
Voltage Fluctuations/ flicker emissions IEC 61000-3-3	Complies	
		WARNING: This system is intended for use by healthcare professionals only. This system may cause radio interference or disrupt nearby equipment's operation. It may be necessary to take mitigation measures, such as reorienting or relocating the system or shielding the location

Guidance and Manufacturer's Declaration - ELECTROMAGNETIC IMMUNITY

Immunity Test	IEC 60601 Test level	Compliance Level	Electromagnetic Environment - Guidance
Electrostatic Discharge (ESD) IEC 61000-4-2	±8kV contact, ±15kV air	±8kV contact, ±15kV air	Floors should be wood, concrete, or ceramic tile. If floors are covered with synthetic material, there should at least be 30% relative humidity.
Electrical fast transient/burst IEC 61000-4-4	±2kV for power supply lines, ±1 kV for SIP/ SOP lines (if applicable)	±2kV line to ground,	Mains power quality should be that of a typical commercial or hospital environment.
Surge IEC 61000-4-5	±1kV differential mode ±2kV common mode	±1kV differential mode Class II equipment	Mains power quality should be that of a typical commercial or hospital environment.
Voltage dips, short interruptions, and voltage variations on power supply input lines IEC 61000-4-11	0% UT for 0.5 cycle 0% UT for 1 cycle 70% UT for 25/30 cycles 0% UT for 250/300 cycles	0% UT for 0.5 cycle 0% UT for 1 cycle 70% UT for 25/30 cycles 0% UT for 250/300 cycles	Mains power quality should be that of a typical commercial or hospital environment. If the user of the transmitter requires continued operation during power mains interruptions, it is recommended that the Wireless Transmitter be powered by an uninterruptible power supply or a battery.
Power frequency (50/60Hz) magnetic field IEC 61000-4-8	30 A/m	30 A/m	Power-frequency magnetic fields should be at levels characteristic of a typical location in a typical commercial or hospital environment.
NOTE: UT is the AC mains voltage prior to application of the test level			

Guidance and Manufacturer's Declaration – ELECTROMAGNETIC IMMUNITY FOR PROFESSIONAL HEALTHCARE FACILITY ENVIRONMENT, IEC 60601-1-2 Ed.4.1

Immunity Test	IEC 60601 Test level	Compliance Level	Electromagnetic Environment - Guidance
Conducted RF IEC 61000-4-6	6 Vrms in ISM bands between 150 kHz to 80 MHz 3 Vrms 150 kHz to 80 MHz	6 Vrms in ISM bands between 150 kHz to 80 MHz 3 Vrms 150 kHz to 80 MHz	Portable and mobile RF communications equipment should be used no closer to any part of the SL11 Camera Unit and MD11 Wireless Receiver system, including its cables, than the recommended separation distance calculated from the equation applicable to the frequency of the transmitter.
Radiated RF IEC 61000-4-3	3V/m 80MHz to 2.7GHz	3V/m 80MHz to 2.7GHz	<p>Recommended Separation Distance</p> <p>$d = 2\sqrt{P}$ 80 MHz to 2.7 GHz</p> <p>where P is the maximum output power rating of the transmitter in watts (W) according to the transmitter manufacturer and d is the recommended separation distance in meters (m). Field strengths from fixed RF transmitters, as determined by an electromagnetic site survey (a), should be less than the compliance level in each frequency range (b).</p> <p>Interference may occur in the vicinity of equipment marked with the following symbol:</p> <div style="text-align: center;">  </div>

(a) Field strengths from fixed transmitters, such as base stations for radio (cellular/cordless) telephones and land mobile radios, amateur radio, AM and FM radio broadcasts, and TV broadcasts, cannot be predicted theoretically with accuracy. An electromagnetic site survey should be considered to assess the electromagnetic environment due to fixed RF transmitters. If the measured field strength in the location in which the SL11 Camera Unit and MD11 Wireless Receiver are used exceeds the applicable RF compliance level above, the display and transmitter should be observed to verify normal operation. If abnormal performance is observed, additional measures may be necessary, such as reorienting or relocating the SL11 Camera Unit and MD11 Wireless Receiver

(b) Over the frequency range 150 kHz to 80 MHz, field strengths should be less than 3 V/m

Tested Specifications for Immunity to RF Wireless Communications Equipment

	Test Frequency (MHz)	Band A (MHz)	Service	Modulation	Immunity Test Level
Proximity fields from RF wireless communications equipment	385	380-390	TETRA 400	Pulse modulation b) 18Hz	27 V/m
	450	430-470	GMRS 460, FRS 460	FM c) ± 5 kHz deviation 1 kHz	28 V/m
	710	704-787	LTE Band 13, 17	Pulse modulation b) 217 Hz	9 V/m
	745				
	780				
	810	800-960	GSM 800/900 TETRA 800 iDEN 820 CDMA 850 LTE Band 5	Pulse modulation b) 18 Hz	28 V/m
	870				
	930				
	1720	1700-1990	GSM 1800 CDMA 1900 GSM 1900 DECT LTE Band 1,3, 4,25; UMTS	Pulse modulation b) 217 Hz	28 V/m
	1845				
	1970				
	2450	2400-2570	Bluetooth, WLAM, 802.11 b/g/n, RFID 2450, LTE Band 7	Pulse modulation b) 217 Hz	28 V/m
	5240	5100-5800	WLAN 802.11 a/n	Pulse modulation b) 217 Hz	9 V/m
	5500				
5785					
IEC 61000-4-39 Immunity to magnetic fields in close proximity	65 A/m 134.2 kHz 7.5 A/m 13.56 MHz	NFC	NFC		65 A/m 134.2 kHz 7.5 A/m 13.56 MHz

Note: Portable RF Communication equipment should be used no closer than 30cm to the SL11 Camera Unit and MD11 Wireless Receiver System. Otherwise, degradation of the performance of this equipment could result.

(a) For some services, only the uplink frequencies are included.

(b) The carrier shall be modulated using a 50 % duty cycle square wave signal.

(c) As an alternative to FM modulation, the carrier may be pulse modulated using a 50 % duty cycle square wave signal at 18 Hz. While it does not represent actual modulation, it would be worst case.